

4
DRAWINGS MADE IN THIRD ANGLE PROJECTION
THIS DRAWING IS UNPUBLISHED. RELEASED FOR PUBLICATION ,19
© COPYRIGHT 19 BY AMP INCORPORATED. ALL INTERNATIONAL RIGHTS RESERVED.

LOC	DIST	P	F	ZONE	LTR	DESCRIPTION	DATE	APPD
CE	16				0	NPR 84-90.	1/29/88	DK

1. DIMENSIONS IN [] ARE IN INCHES

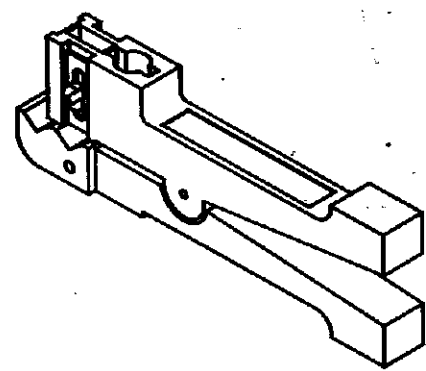
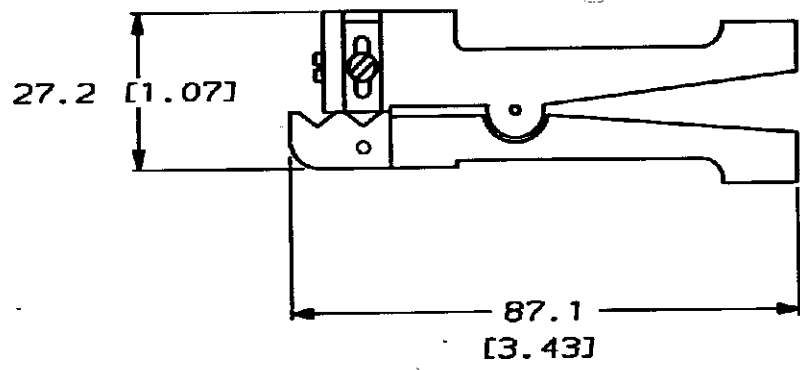
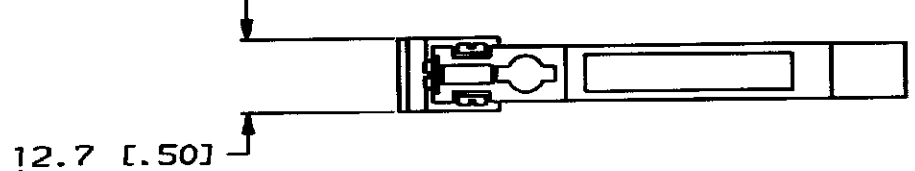

METRIC

		501198-1	
		PART NO	
DO NOT SCALE PRINT. UNLESS SPECIFIED DIMENSIONS IN mm TOLERANCES ON: 1 PLC DEC ± 0.8 (.03) 2 PLC DEC ± - ANGLES ± -		DR: <i>[Signature]</i> 1-29-88	AMP INCORPORATED Harrisburg, Pa. 17105
MATERIAL -		CHK: <i>[Signature]</i> 7-1-88	NAME
FINISH -		APP: <i>[Signature]</i> 2-1-88	CABLE STRIPPER, OPTIMATE
APPLICATION SPEC -		SIZE B	FSCN NO 00779
WEIGHT -		SCALE NTS	DRAWING NO 501198
			SHEET 1 OF 1

CUSTOMER DRAWING